

Automatic top surface labeling machine



Model : YQ112

Specification

Speed : 20-150 Pcs / min

Labeling Accuracy : $\pm 1\text{mm}$

Product size : (L) : 20-400 (W) : 20-200 (H) : 0-100mm

Label size : (L) 15-260 mm (W) 15-150 mm

Label roll : (OD) 300 , (ID) 76mm

Voltage : AC220V,50/60HZ

Size and Weight : 700*2100*1500mm /190Kg

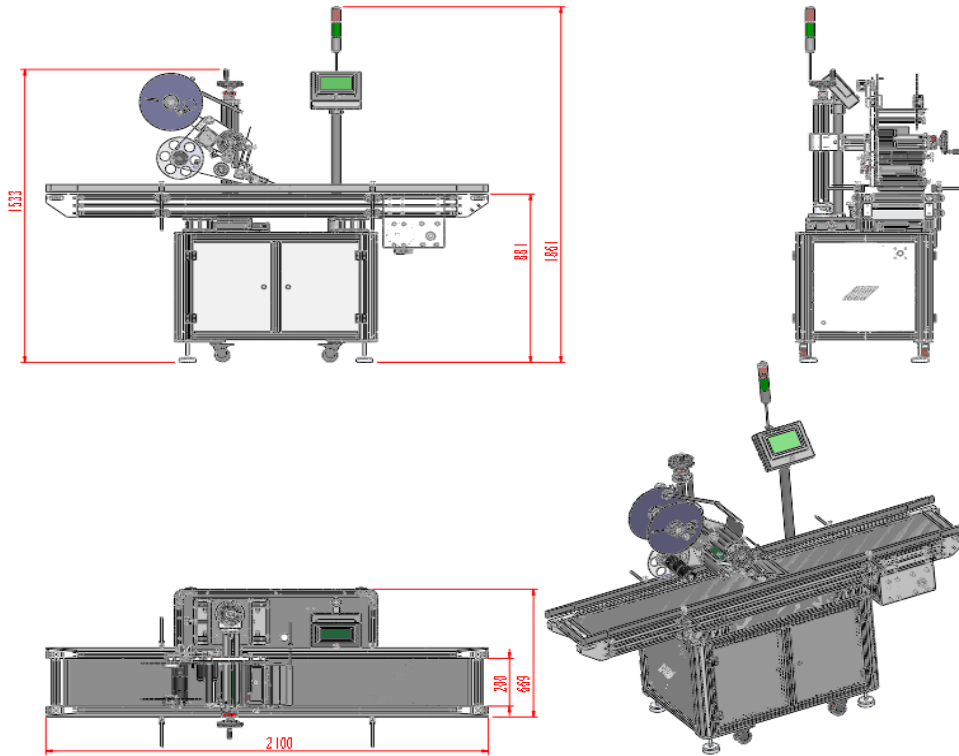

Electrical Configuration

Name	Unit	Brand
Touch screen	1	Weinview
Traction motor	1	Leadshine stepper motor
Motor drive	1	(Taiwan)
Conveyor motor	1	(Taiwan)
Detection label sensor	1	Sick (Germany)
PLC	1	Mitsubishi
The sensor detection products	1	Panasonic Industrial Devices
Switch	2	Schneider (France)
Relays	4	Schneider (France)
Divided bottle motor	1	(China)

Organization

Name	Unit	Main material
Electronic control box	1	Aluminum, stainless steel
Cover Standard mechanism	1	Stainless steel, sponge
Labeling mechanism	1	Stainless steel, aluminum
Divided bottle mechanism	1	Stainless steel, aluminum
Touch screen mechanism	1	Stainless steel, aluminum
Lateral adjustment	1	Stainless steel, aluminum
adjustment mechanism	1	Stainless steel, aluminum
delivery mechanism	1	Stainless steel, aluminum